





*Il valore di una porta, il lavoro di una vita.*

# INDICE

---

## L'AZIENDA

01

## COLLEZIONI

---

05	Minimal
53	Time
77	Fusion
89	Wood

## COMPLEMENTI D'ARREDO

101	Filomuro
105	Armadi a Muro
106	Boiserie

## VERSIONI

109	Telai
111	Sensi di apertura
115	Finiture
117	Essenze legno - Laccati

---



# L'AZIENDA

---

Cofas spa è una realtà con oltre trent'anni di esperienza nella produzione di porte in legno per interni.

Un'azienda situata nella repubblica più antica del mondo: San Marino.

Capacità produttiva di oltre 20.000 porte all'anno, macchinari a controllo numerico all'avanguardia permettono di personalizzare al massimo le porte di casa vostra.

Ogni singolo elemento viene realizzato rispondendo alle necessità del cliente.

Siamo presenti nei mercati d'Italia, Francia, Lussemburgo, Australia e Russia.



cofas  
SAN MARINO



- 
- **Qualità dei materiali:** L'attenta selezione della materia prima ci permette di proporre a tutti i nostri clienti il meglio di ciò che offre madre natura, nel totale rispetto di quest'ultima. Tutti i nostri prodotti sono il risultato dell'unione tra l'artigianalità e i più moderni processi industriali.
  - **Flessibilità:** La nostra flessibilità ci permette di soddisfare tutte le vostre richieste specialmente quelle su misura. Ogni vostro progetto viene elaborato e seguito dai nostri esperti tecnici capaci di stimolare la vostra idea di casa
  - **Amore per il dettaglio:** La cura delle finiture e il desiderio di rispondere alle nuove proposte di design sono il fondamento del nostro marchio di garanzia



**MINIMAL**

# MINIMAL

---

La collezione Minimal è nata per combinare perfettamente modernità, linee essenziali e il fascino del vero legno. I giochi di tranciato, le incisioni e i contrasti di venature realizzati manualmente da esperti intarsiatori rendono ogni porta unica e capace di soddisfare ogni vostro progetto.

## CARATTERISTICHE TECNICHE

---

La collezione Minimal compone la nostra più ampia gamma di prodotti lineari e moderni. L'anta è tamburata e viene realizzata con MDF da 4 mm e massello perimetrale in essenza, per garantire la massima stabilità nel tempo.

L'intera gamma Minimal è proposta in tutte le colorazioni RAL e colori a campione, con finitura naturale o lucida-brillante.

Su tutte le porte di questa collezione sono disponibili vari sensi di apertura.



TN4 frassino a poro aperto laccato  
RAL a campione - telaio quadro  
cornice liscio 10

---





TN1 laccato opaco RAL a campione  
telaio squadro inverso - cornice liscio 10



TN4 frassino a poro aperto laccato RAL 7044/N - scorrevole esterno muro a due ante modello DIVA - maniglione inciso su massello

Minimal Time Fusion Wood







TN4 rovere sbiancato 48/N - scorrevole interno muro  
telaio squadro - cornice liscio 10

Minimal Time Fusion Wood



TN4 frassino olivato decapè  
telaio squadro - cornice liscio 7



TN28 laccato opaco RAL 9010/N - vetro satinato chiaro  
telaio squadro - cornice liscio 7

Minimal Time Fusion Wood



TN1 laccato opaco BIANCO COFAS/N  
telaio squadro - cornice liscio 7



TN1 laccato opaco RAL 9001/N  
telaio squadro - cornice a progetto

Minimal Time Fusion Wood



TN 155F frassino a poro aperto alternato  
laccato liscio brillante RAL 9010/N - scorrevole  
esterno muro modello MAGIC



TN80 frassino a poro aperto laccato RAL 9010/N  
telato squadra - cornice liscio 10

Minimal Time Fusion Wood



TN121 laccato opaco RAL 3020  
telaio squadro - cornice liscio 7





TN138 laccato opaco RAL 7047/N  
telaio squadro - cornice liscio 7

Minimal Time Fusion Wood



TN124 laccato opaco RAL 9010/N  
telaio squadra - cornice liscio 7



TN410 castagno rigato effetto naturale/N  
telaio squadro - cornice liscio 10

Minimal Time Fusion Wood



TN200 laccato opaco BIANCO COFAS/N  
vetro bianco latte extrachiario  
telaio squadro - cornice liscio 10





TN6 canaletto 60/N - telaio squadro  
cornice liscio 7 complanare interno

TN17 toulipier 39/N  
felaio squadro - cornice liscio 7

---





TN4 rovere effetto naturale 52/N  
telaio squadro - cornice liscio 10

TN3 tanganika 30/N - telaio R50  
cornice curvo - sistema rototraslante

---







TN1 laccato opaco RAL a campione  
telaio squadro - cornice liscio 10

TN5 noce nazionale 41/N  
telaio squadro - cornice liscio 7

---



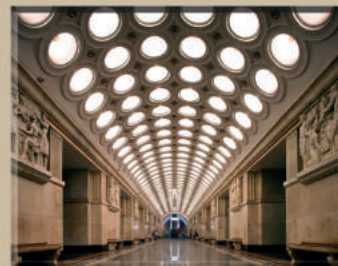

TN68 castagno 33/N  
telaio squadro - cornice liscio 7

TN420 frassino decapè a capione  
telaio squadro - cornice liscio 10

---

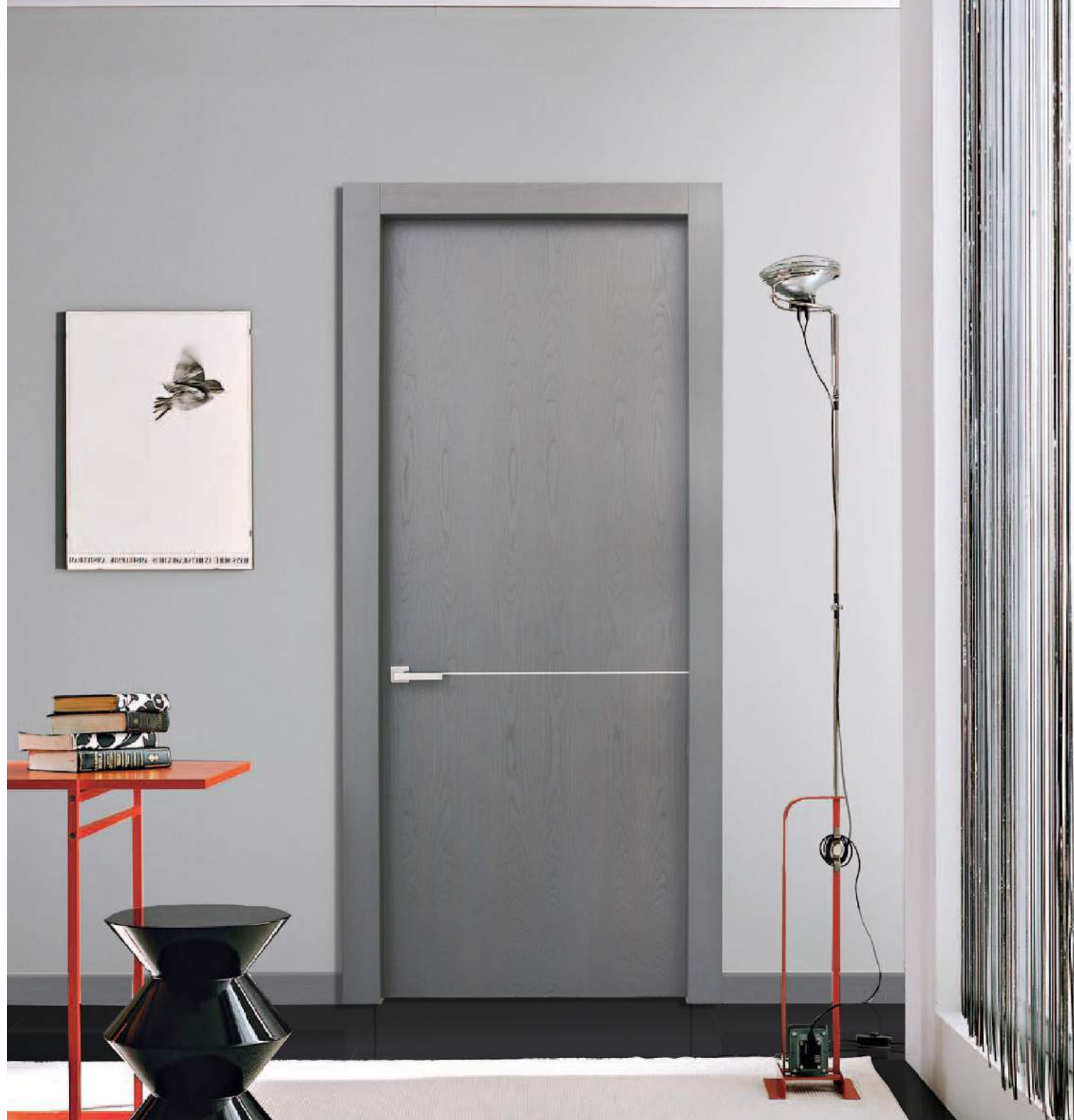



TN409 canaletto 60/N  
telaio squadro - cornice liscio 10

TN405 frassino decapè cofas/N  
telaio R10 - cornice curvo

---





TN401 rovere tinto wengè 50/N  
telaio squadro - cornice liscio 10

TN29 ciliegio 49/N  
telaio squadro - cornice liscio 7

---







TN160 frassino a poro aperto  
laccato RAL 9010/N  
telaio squadro - cornice liscio 10

TN404 laccato opaco BIANCO COFAS/N  
telaio squadro - cornice liscio 7

---





TN133 laccato opaco RAL 7047/N  
telaio squadro - cornice liscio 10

TN115 laccato opaco RAL 1019/N  
telaio squadro - cornice liscio 10

---





TN147 frassino a poro aperto  
laccato RAL 5002  
telaio squadro  
cornice liscio 7 complanare interno





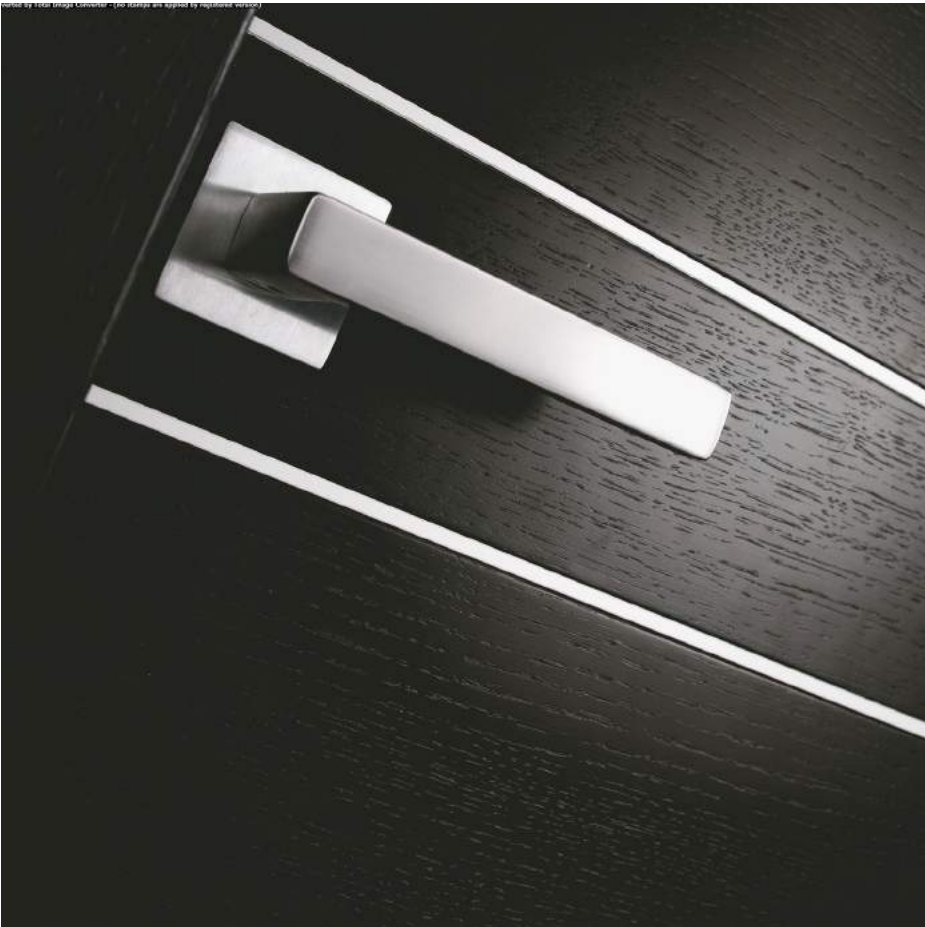





# PORTE LISCE

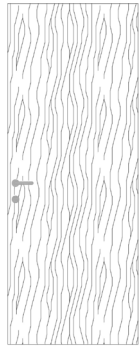

TN1

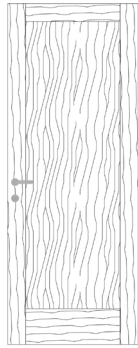

TN2

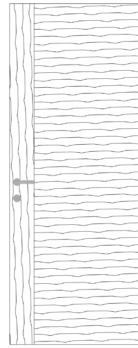

TN3

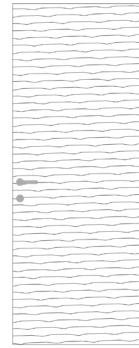

TN4

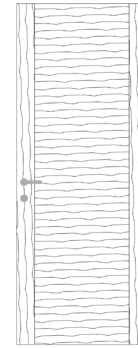

TN5

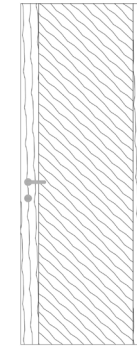

TN6

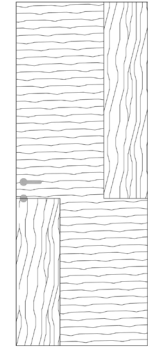

TN8

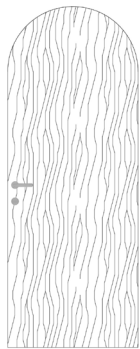

TN90

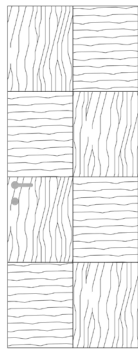

TN91

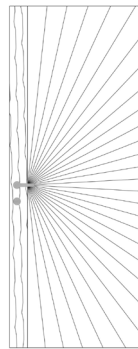

TN92

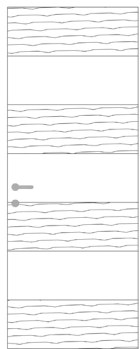

TN155

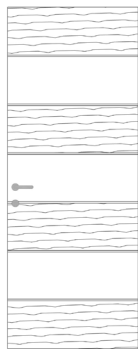

TN155F



TN156F

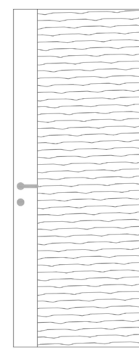

TN158

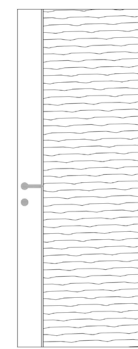

TN158F

VERSIONE SPECIAL

# PORTE CON INCISIONI

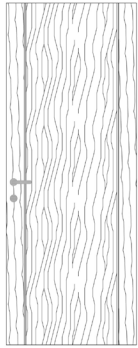

TN7

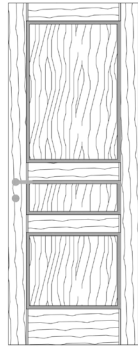

TN9

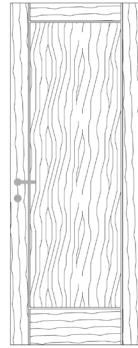

TN13



TN14

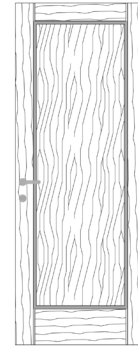

TN15



TN16

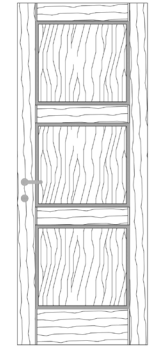

TN17

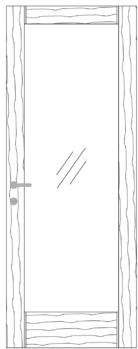

TN18

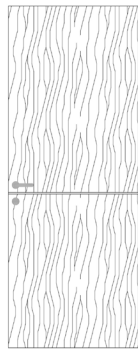

TN19

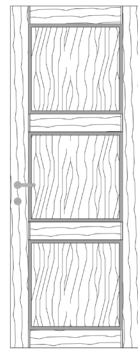

TN73

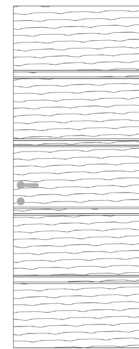

TN80

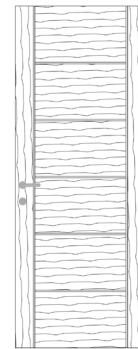

TN99

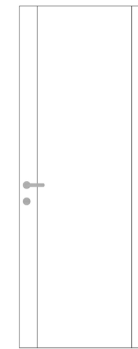

TN100

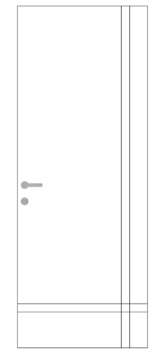

TN101

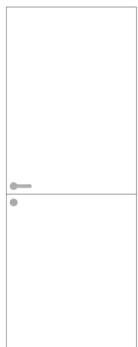

TN102

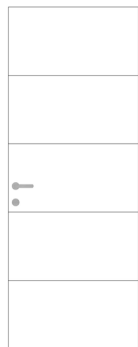

TN103

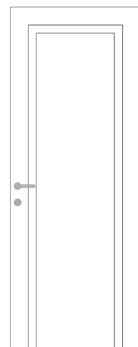

TN104



TN105

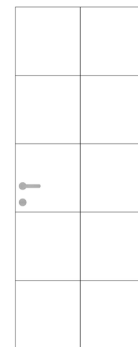

TN106

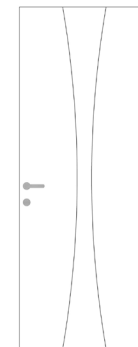

TN107

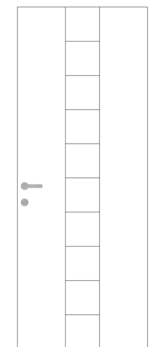

TN108



TN109

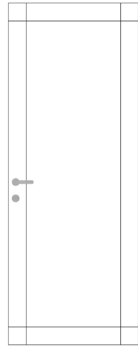

TN110



TN111

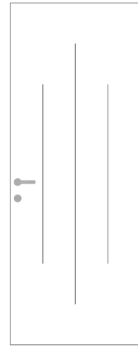

TN112

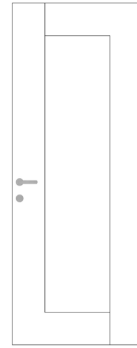

TN113



TN114

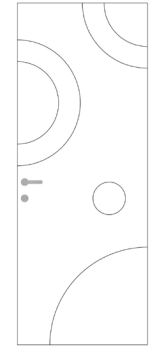

TN115

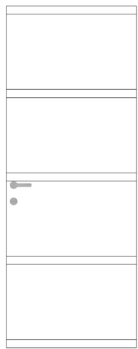

TN116

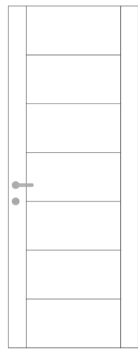

TN117

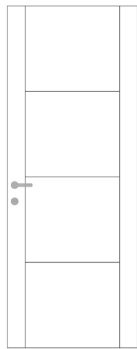

TN118

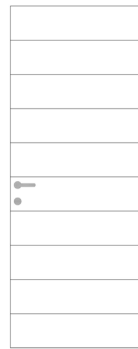

TN119



TN120

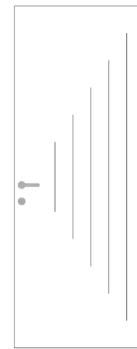

TN121

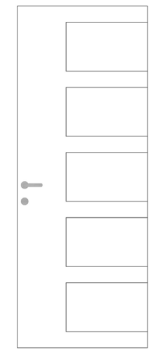

TN122

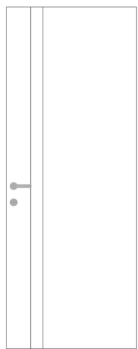

TN123



TN124

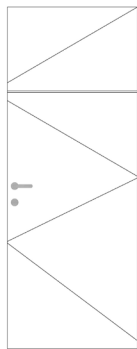

TN125

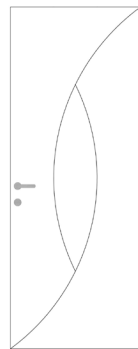

TN126

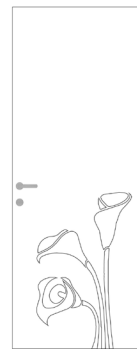

TN127

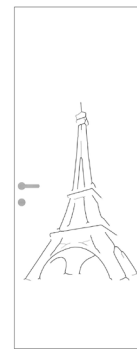

TN133

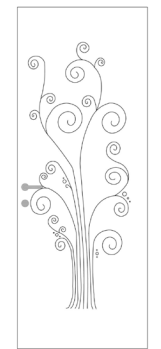

TN137

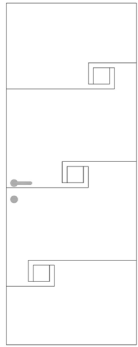

TN138

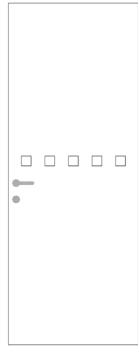

TN139

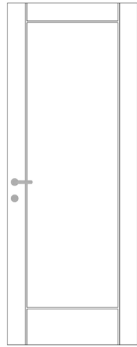

TN140

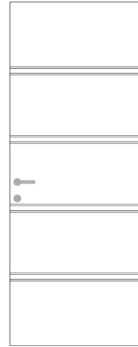

TN141

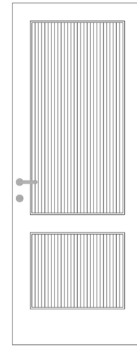

TN143

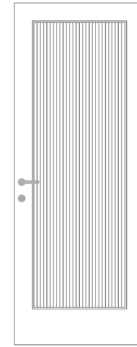

TN144

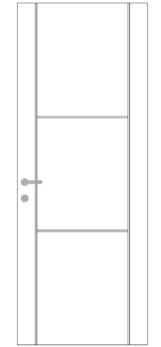

TN145

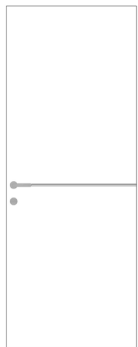

TN146

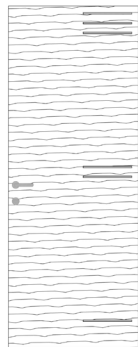

TN147

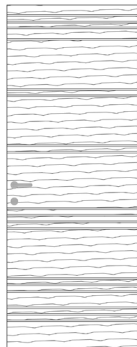

TN148

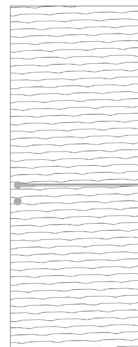

TN149

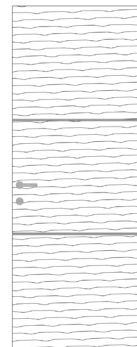

TN150

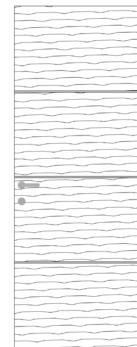

TN151

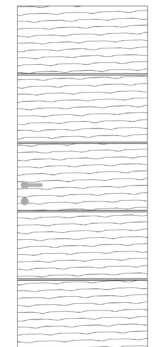

TN152

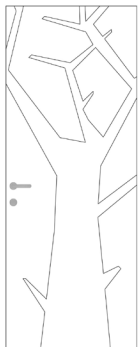

TN157

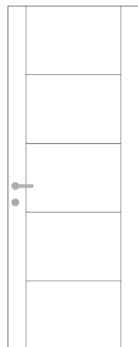

TN159

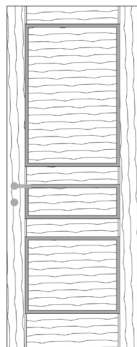

TN160

# PORTE CON INSERTI IN ALLUMINIO

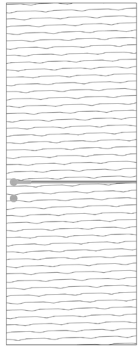

TN400

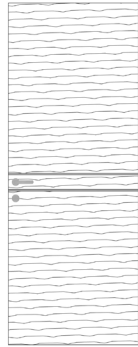

TN401

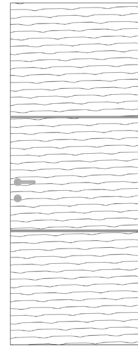

TN402

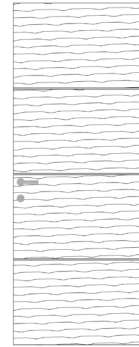

TN403

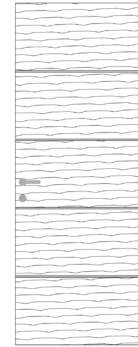

TN404

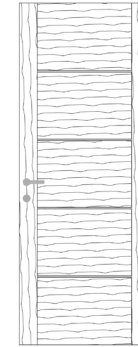

TN405

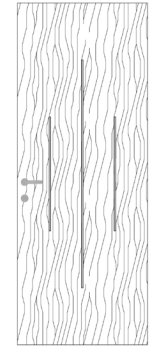

TN406

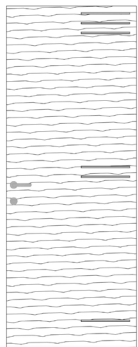

TN407

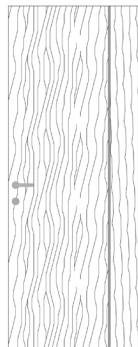

TN408

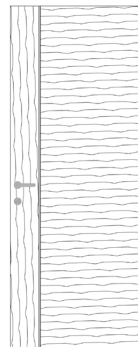

TN409



TN410

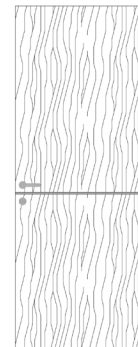

TN420

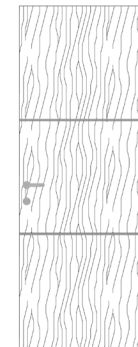

TN421

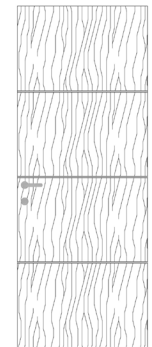

TN422

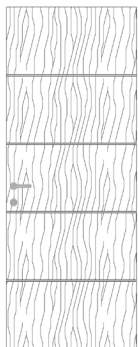

TN423

# PORTE BUGNATE

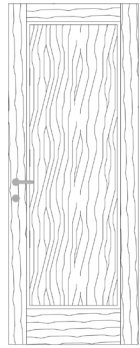

TN27

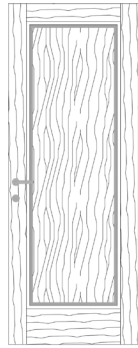

TN29

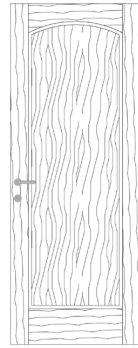

TN31

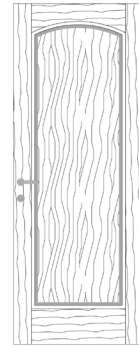

TN33



TN35



TN36

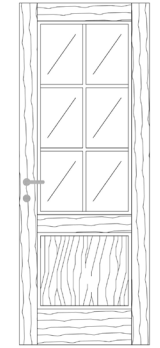

TN37



TN38



TN39



TN40



TN41



TN42



TN43

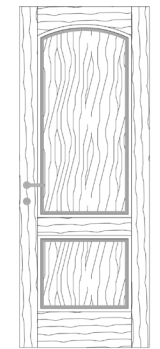

TN44

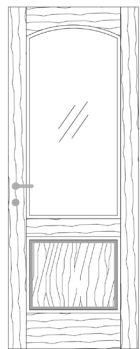

TN45



TN46

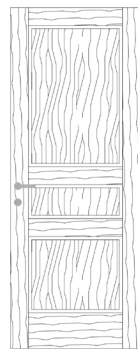

TN47



TN50

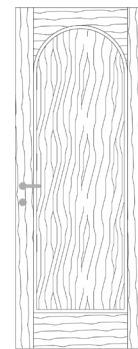

TN59



TN62

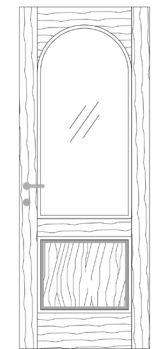

TN63

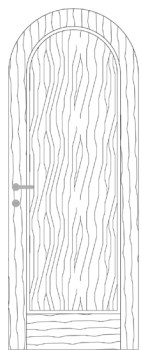

TN65

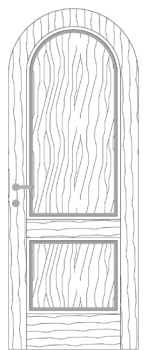

TN68

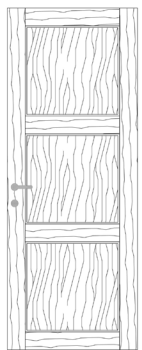

TN72

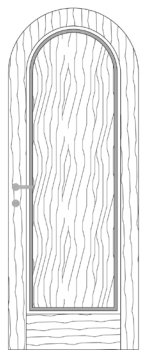

TN74

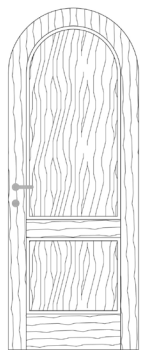

TN75

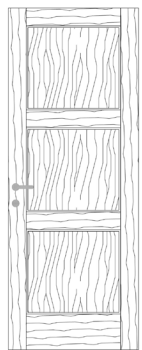

TN93

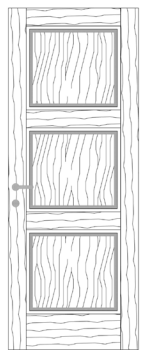

TN94

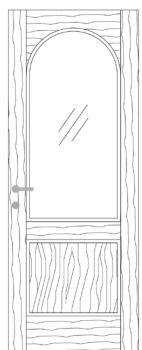

TN95



# PORTE VETRO

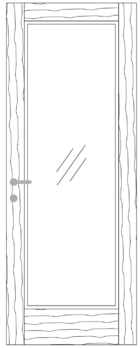

TN28



TN28V

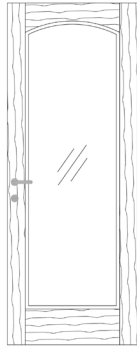

TN32



TN60

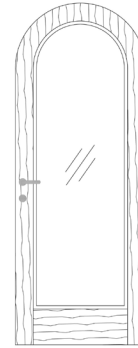

TN66

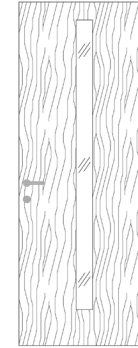

TN200

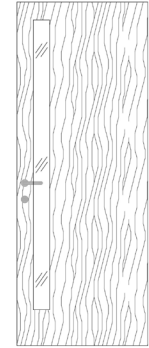

TN201

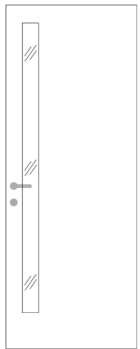

TN201V

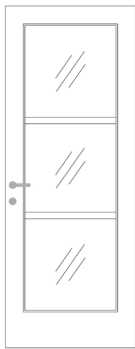

TN203

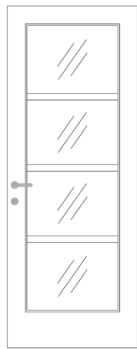

TN204

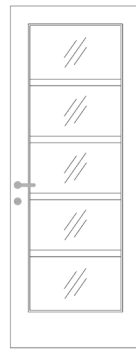

TN205

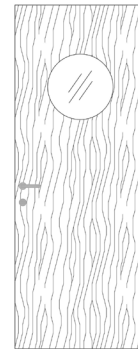

TN206

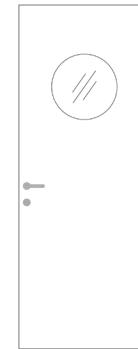

TN206V

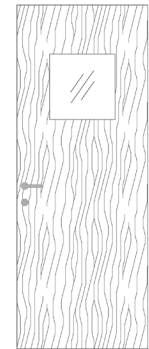

TN207



**TIME**

# TIME

---

La collezione Time è nata per riportare nella nostra vita le passioni e il desiderio.

Porte creative e di attualità, personalizzabili, adatte a qualsiasi ambiente, dal classico al moderno.

## CARATTERISTICHE TECNICHE

---

La collezione comprende un vasto catalogo di modelli differenziati tra MDF da 6 mm e MDF da 12 mm, dalla pantografatura più classica a quella più moderna ad angolo retto. L'applicazione del vetro si differenzia tra fermavetro riportato da un lato o vetro ad infilare.

L'intera gamma Time è proposta in tutte le colorazioni RAL.

Su tutte le porte di questa collezione sono disponibili vari sensi di apertura e la massima possibilità di personalizzazione.



PN35 frassino a poro aperto  
laccato RAL 7047/N - telaio squadro  
cornice liscio 10  
pantografatura modello C  
vetro satinato chiaro  
battente a due ante asimmetriche





PN25F laccato opaco RAL 7047/N  
telaio squadro - cornice liscio 10  
pantografatura modello B





PN14 laccato opaco RAL 9010/N  
felaio squadro - cornice liscio 7  
pantografatura modello B  
vetro satinato chiaro



PN28 laccato opaco RAL 1013/N  
telaio squadro - cornice liscio 7  
pantografatura modello 1  
sistema a libro  $\frac{1}{2} + \frac{1}{2}$



PN13 frassino laccato  
a poro aperto RAL 9001/N  
telaio squadro - cornice liscio 7  
pantografatura modello 2



PN28 laccato opaco RAL 1013/N  
pantografatura modello A  
scorrevole esterno muro  
con mantovana in legno

Minimal Time Fusion Wood



PN01 laccato opaco BIANCO COFAS/N  
telaio squadro - cornice liscio 7  
pantografatura modello 4



PN13 laccato opaco RAL a campione  
telaio squadro - cornice liscio 7  
pantografatura modello 2  
sistema a libro 1/3 + 2/3

Minimal Time Fusion Wood



PN39F laccato opaco RAL 9010/N  
telaio squadro - cornice liscio 10  
pantografatura modello C





PN44 laccato antico/N - telaio squadro  
cornice liscio 7 - pantografatura modello 2  
capitello superiore

PN39 laccato opaco RAL 1013/N  
felaio squadro - cornice liscio 7  
pantografatura modello 3







PN04 laccato a mano bicolore con decoro  
telaio squadro - cornice barocco  
pantografatura modello 1

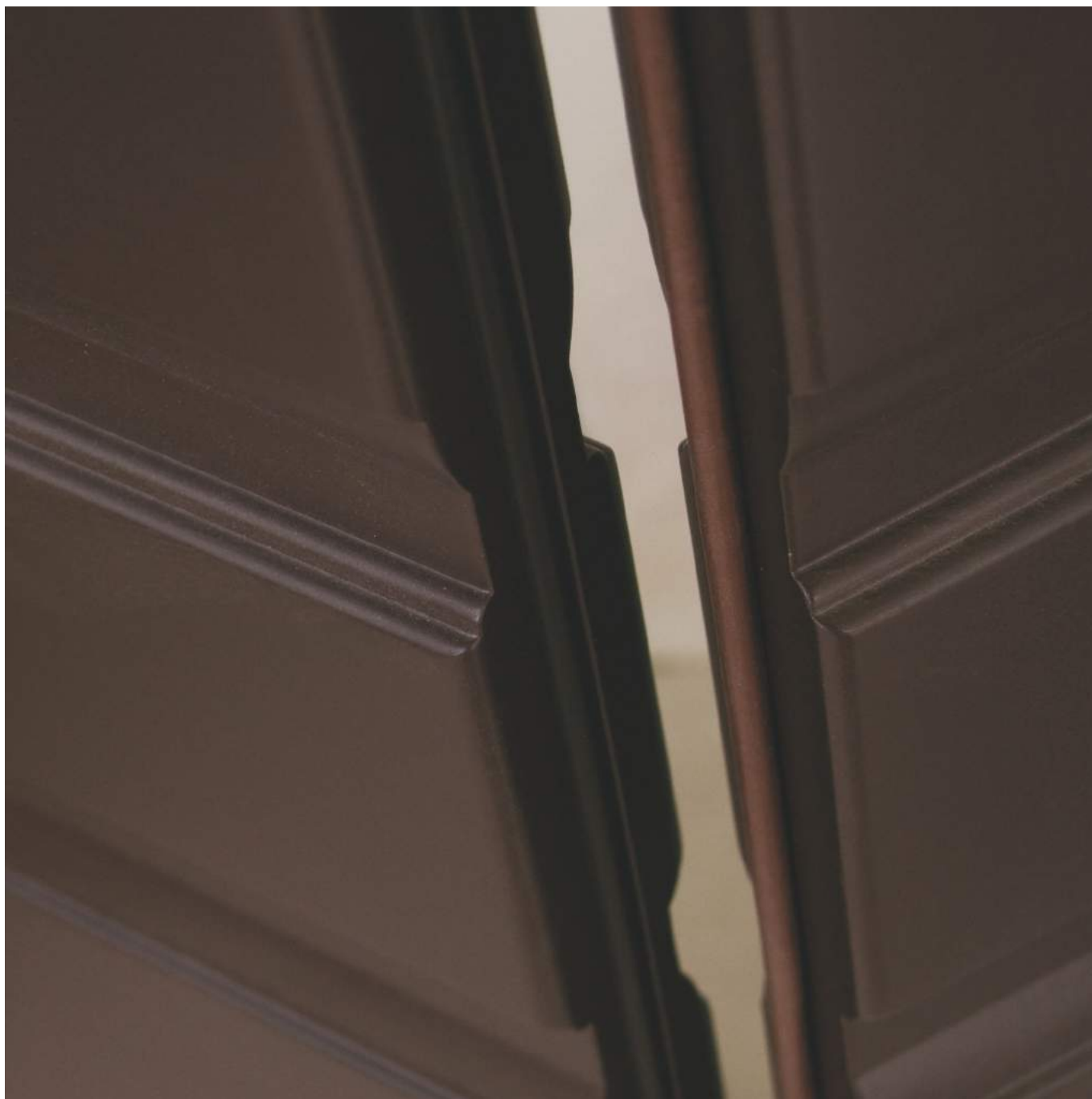





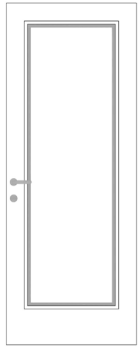

PN01

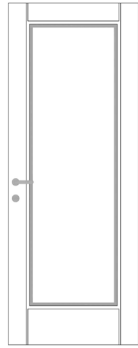

PN01F

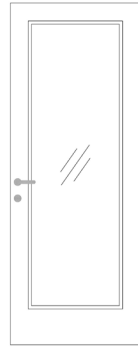

PN02

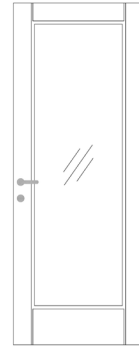

PN02F

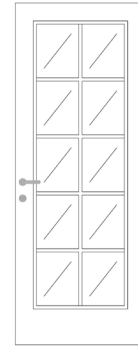

PN03

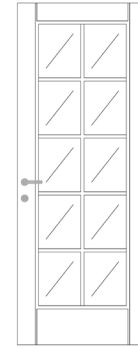

PN03F

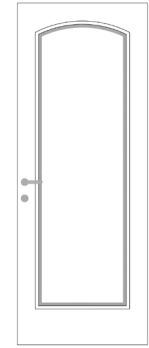

PN04

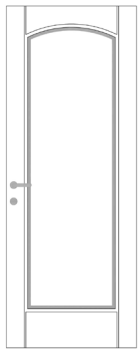

PN04F



PN05

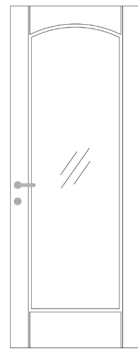

PN05F

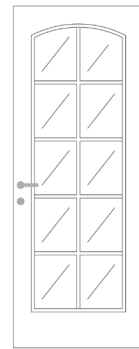

PN06

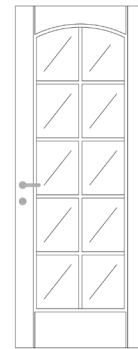

PN06F

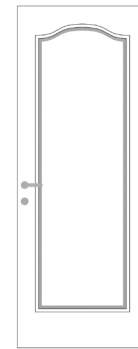

PN07

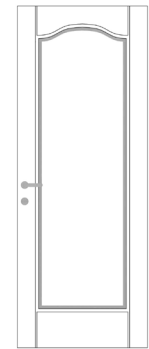

PN07F

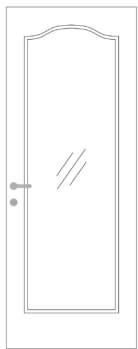

PN08



PN08F

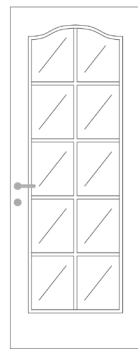

PN09

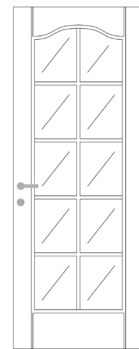

PN09F

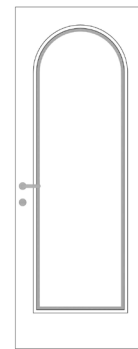

PN10

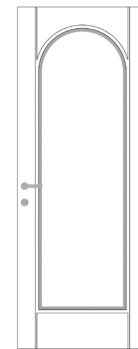

PN10F

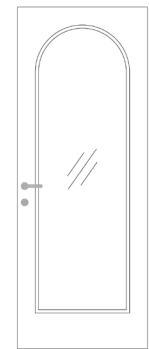

PN11



PN11F

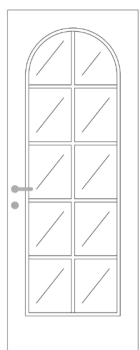

PN12

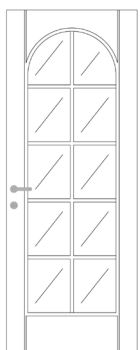

PN12F

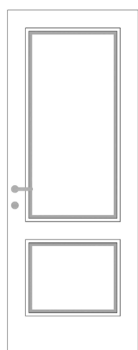

PN13

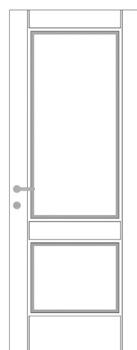

PN13F

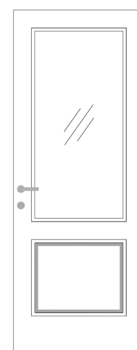

PN14

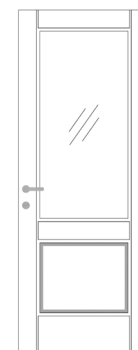

PN14F

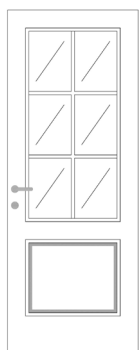

PN15

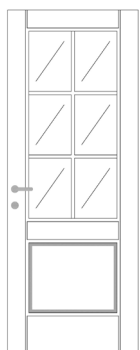

PN15F

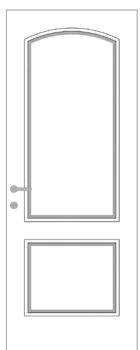

PN16

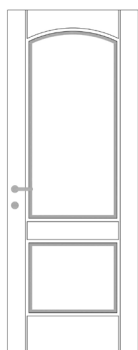

PN16F

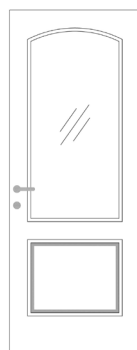

PN17

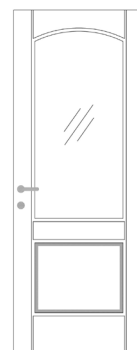

PN17F



PN18



PN18F

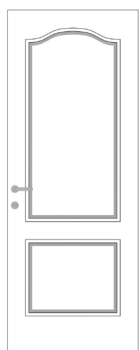

PN19

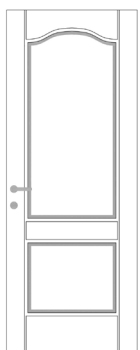

PN19F

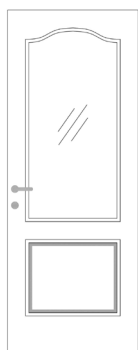

PN20

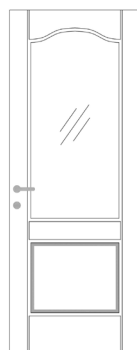

PN20F

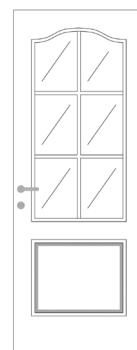

PN21

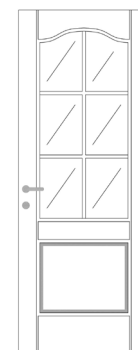

PN21F

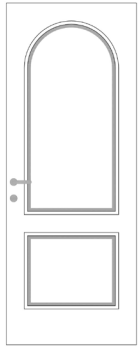

PN22

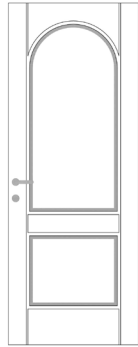

PN22F

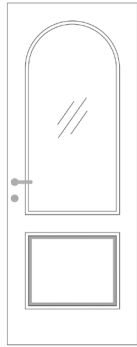

PN23

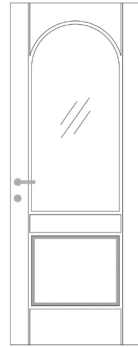

PN23F

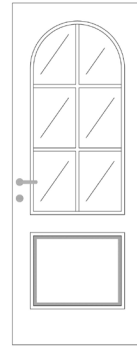

PN24

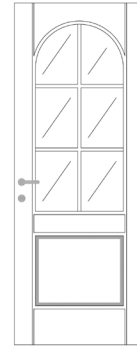

PN24F

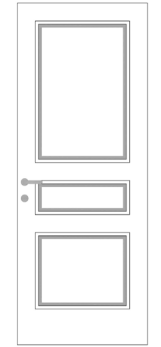

PN25

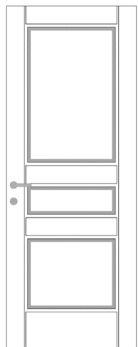

PN25F

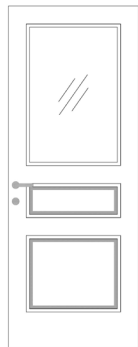

PN26

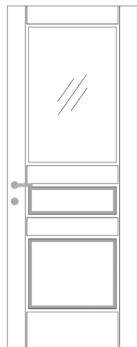

PN26F

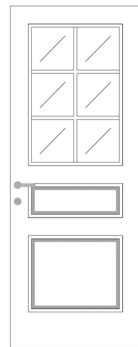

PN27

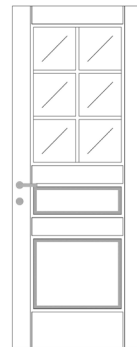

PN27F

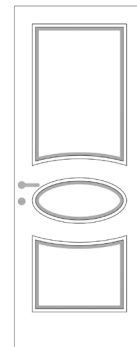

PN28

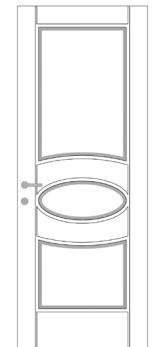

PN28F



PN29

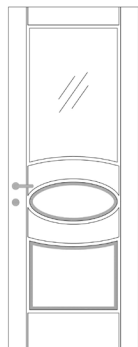

PN29F

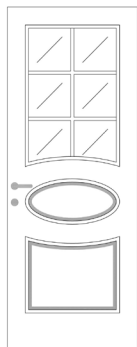

PN30

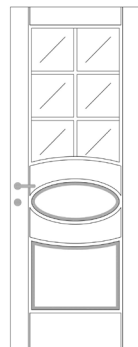

PN30F

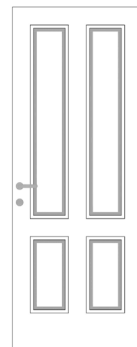

PN31

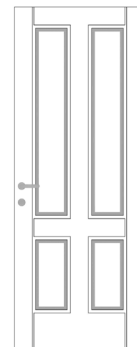

PN31F



PN32

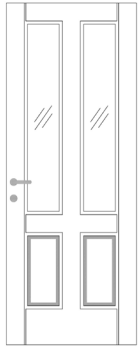

PN32F

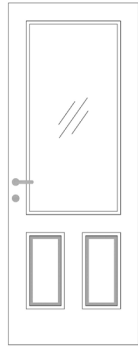

PN33

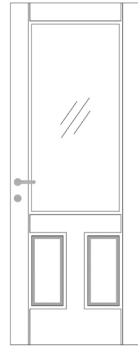

PN33F

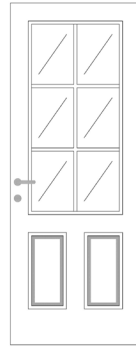

PN34

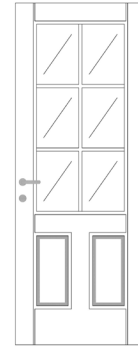

PN34F

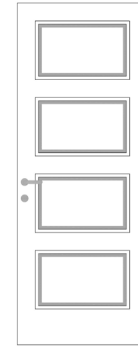

PN35

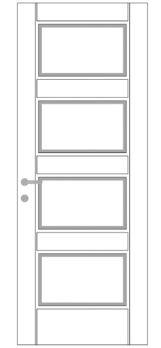

PN35F

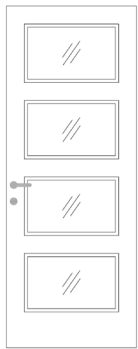

PN36



PN36F

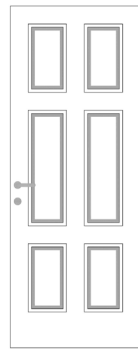

PN37



PN37F

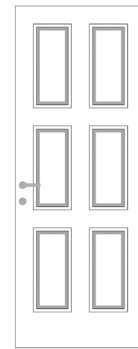

PN38

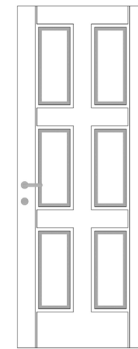

PN38F

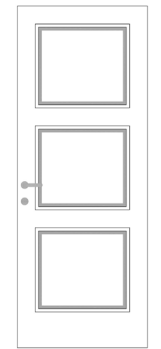

PN39



PN39F

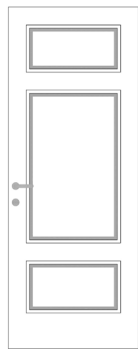

PN40

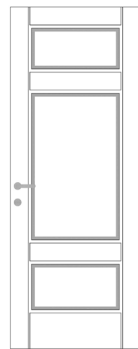

PN40F

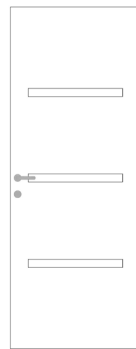

PN41

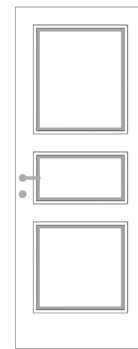

PN42

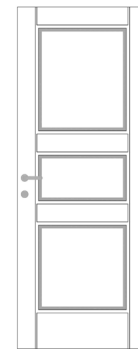

PN42F

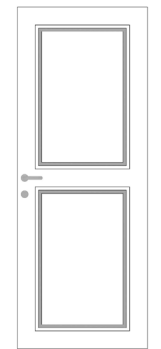

PN43



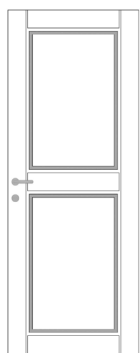

PN43F

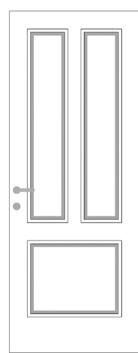

PN44

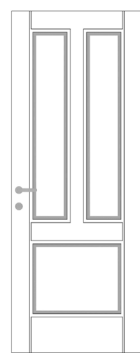

PN44F

**mm 12**



MOD 1



MOD 2



MOD 3



MOD 4

**mm 6**



MOD A



MOD B



MOD C



MOD Y

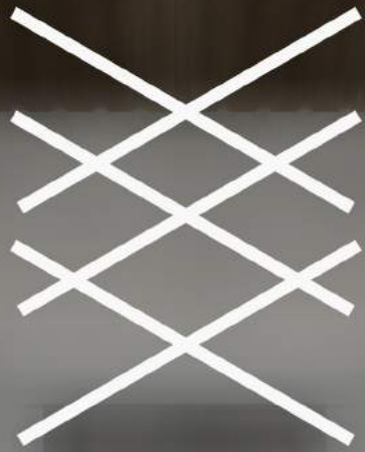

# FUSION

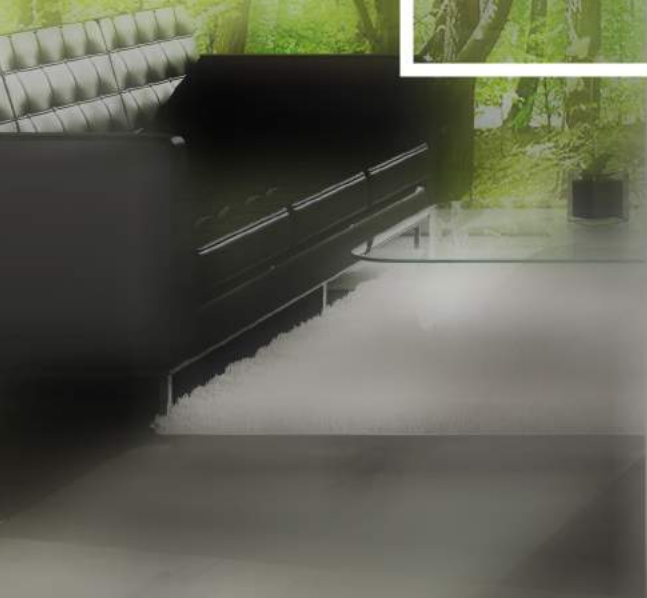
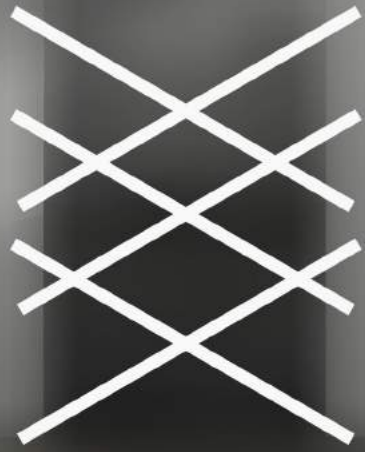

# FUSION

---

La profonda conoscenza dei materiali ci ha permesso di offrirvi un prodotto unico.

Il design nato da una perfetta fusione tra classico e moderno e le finiture di altissimo livello trasmettono una piacevole sensazione di ospitalità. Qualità e convenienza, per un porta di grande prestigio.

## CARATTERISTICHE TECNICHE

---

La struttura in legno listellare massellato permette la massima personalizzazione della porta. Optando tra tre tipologie di profili (squadrato, raggiato o barocco), il cliente ha la possibilità di ottenere un risultato dallo stile più moderno o più classico, a seconda delle esigenze.

L'intera collezione Fusion è proposta in tutte le colorazioni RAL e laccati a campione.

Su tutte le porte di questa collezione sono disponibili vari sensi di apertura e un'elevata possibilità di personalizzazione.



LN30 frassino a poro aperto  
laccato RAL 9010/N - telaio squadro  
cornice liscio 10





LN10 frassino a poro aperto  
laccato RAL 7044/N - telaio squadro  
cornice liscio 10



LN5 laccato opaco BIANCO COFAS/N  
telaio squadro - cornice liscio 7

Minimal Time Fusion Wood



LN1 laccato opaco RAL 7036/N  
telaio squadro - cornice liscio 10







LN11 rovere effetto naturale 52/N  
telaio R30 - cornice liscio 7

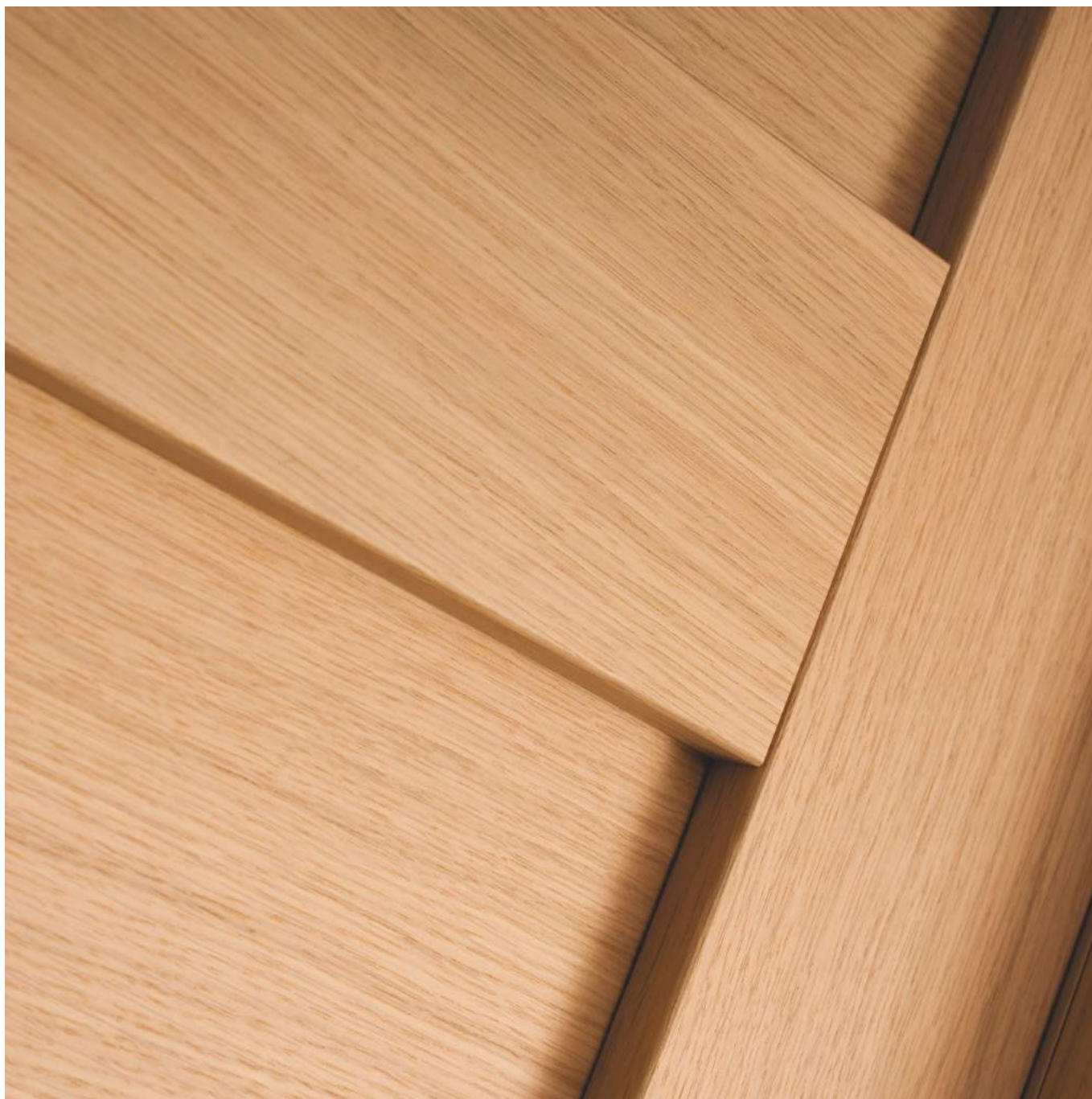



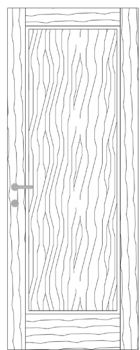

LN1

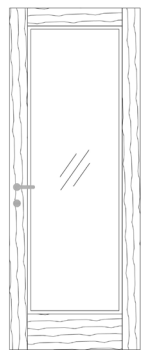

LN2

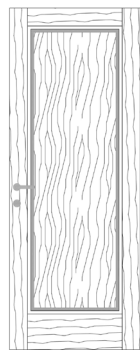

LN3

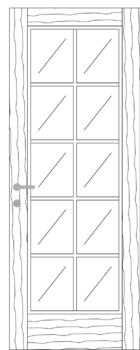

LN4

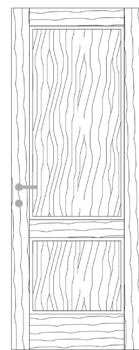

LN5

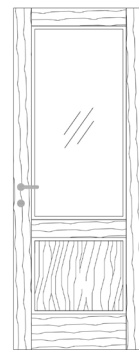

LN6

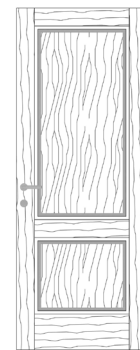

LN7

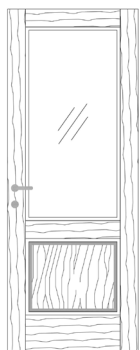

LN8



LN9



LN10

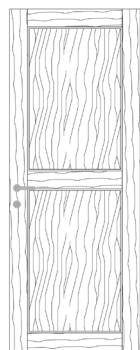

LN11

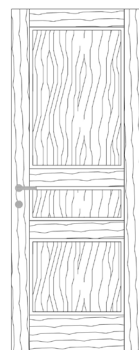

LN12

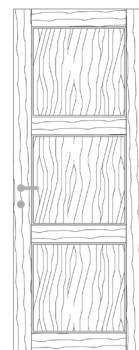

LN13

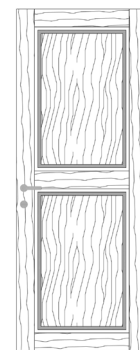

LN14

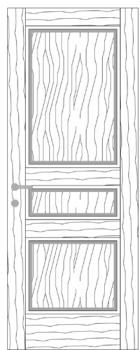

LN15

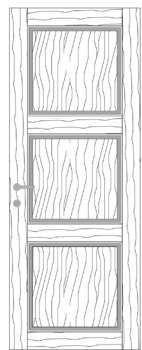

LN16

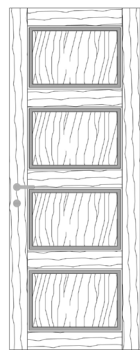

LN17



LN18



LN19

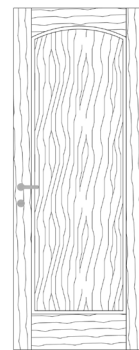

LN20

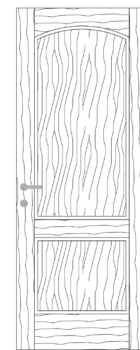

LN21

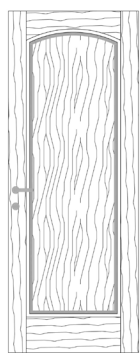

LN22

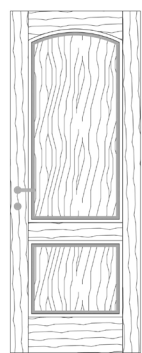

LN23



LN24

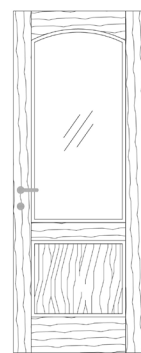

LN25



LN26



LN27



LN28

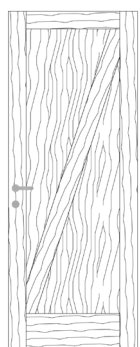

LN29

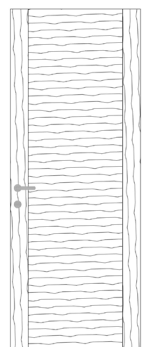

LN30

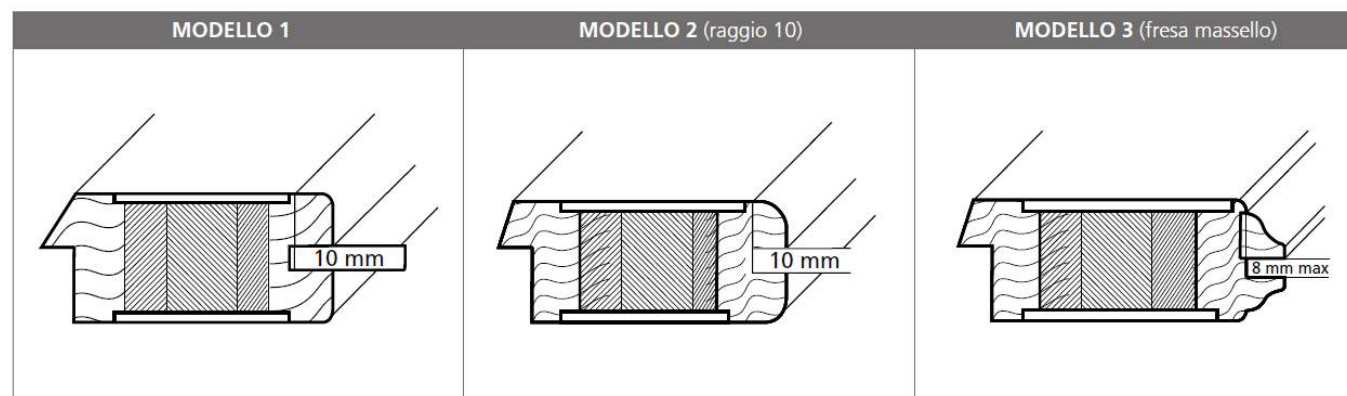

A blurred interior scene featuring a wooden door and a lamp, with the word "WOOD" overlaid in a white frame.

**WOOD**

# WOOD

---

La vera svolta della classica porta in legno massello. COFAS la interpreta in un'ottica originale e astuta, per una collezione forte e dinamica, capace di trasmettere il fascino del legno e tutto il suo calore, sia in tinte chiare che scure. Una porta classica studiata anche per l'ambiente più moderno.

## CARATTERISTICHE TECNICHE

---

Le porte della serie Wood vengono realizzate in vero legno massello. La realizzazione in legno lamellare garantisce la massima stabilità del prodotto.

L'intera collezione Wood è proposta in varie tipologie di effetti legno, sui quali è disponibile un'ampia possibilità di personalizzazione.

Su tutte le porte di questa collezione sono disponibili vari sensi di apertura.



MN4 castagno finitura a cera 56/N  
telaio squadro - cornice barocco







MN20 rovere finitura gomma lacca  
con tarli e bozze 57/N - telaio squadro  
cornice barocco - vetro trasparente

MN4 frassino rusticato finitura a cera  
telaio squadro – cornice liscio 7





MN13 rovere finitura gomma lacca  
con tarli e bozze 57/N  
telaio squadro - cornice barocco

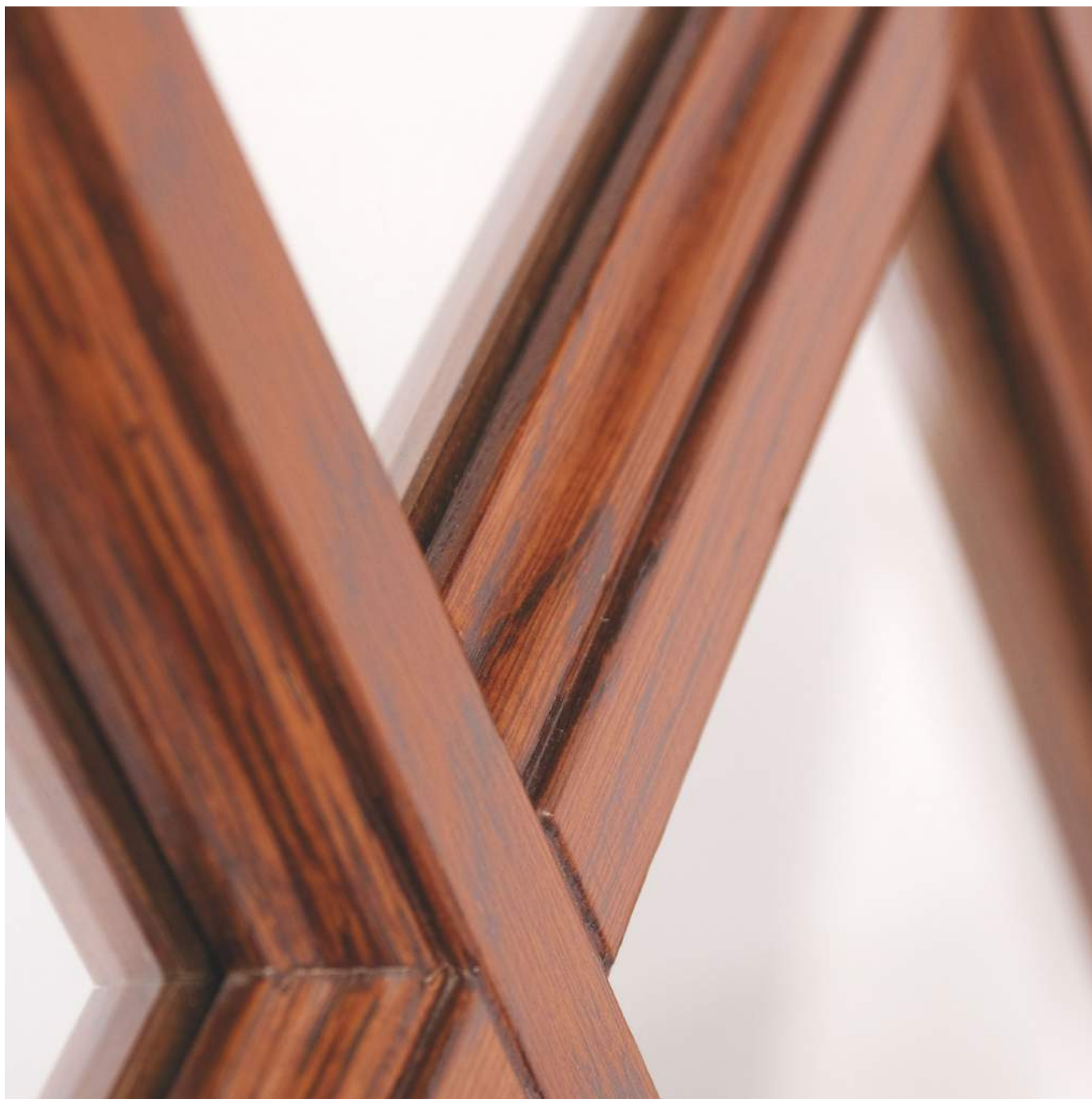



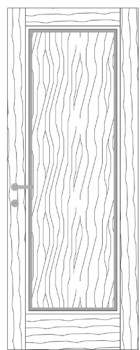

MN1

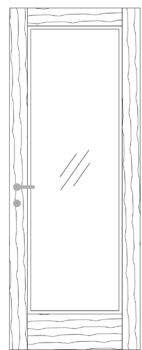

MN2

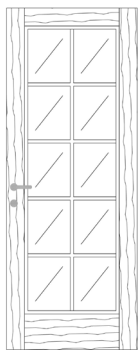

MN3



MN4

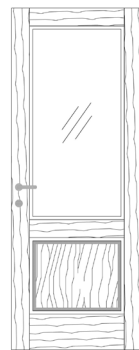

MN5



MN6



MN7

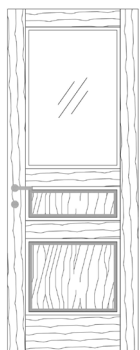

MN8

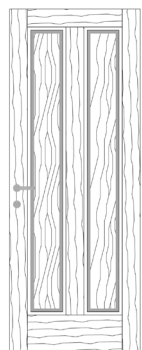

MN9

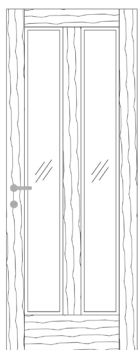

MN10



MN11



MN12

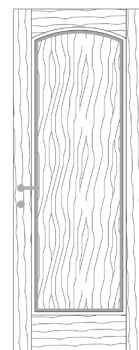

MN13



MN14

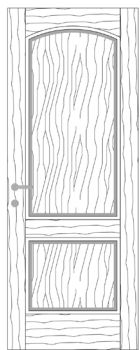

MN15



MN16

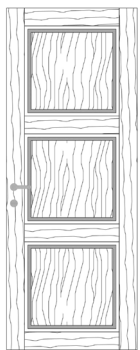

MN17

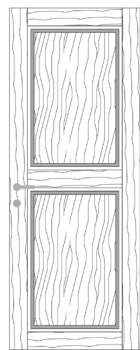

MN18



MN20

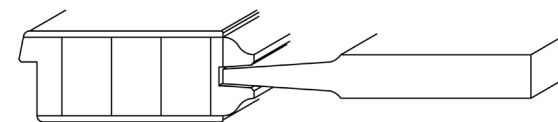





# COMPLEMENTI D'ARREDO





**FILOMURO • ARMADI A MURO • BOISERIE**

# FILOMURO





FILOMURO laccato opaco  
RAL 7036/N

## FILOMURO



Filomuro in zebrano

## FILOMURO



ARMADIO A MURO frassino a poro aperto  
laccato RAL 1013/N

## ARMADI A MURO



BOISERIE canaletto 60/N

## BOISERIE



A close-up, black and white photograph of a mechanical component, possibly a metal part of a machine. The component has a curved, cylindrical shape on the left and a flat, rectangular section on the right. The lighting is dramatic, highlighting the textures and edges of the metal. A solid blue horizontal banner is positioned at the bottom of the image, containing the word 'VERSIONI' in white, bold, uppercase letters.

# VERSIONI





**TELAI • SENSI DI APERTURA • FINITURE • ESSENZE LEGNO / LACCATI**

SQUADRO +  
LISCIO 7

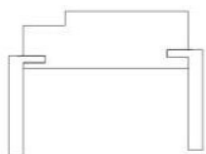

SQUADRO +  
CURVO

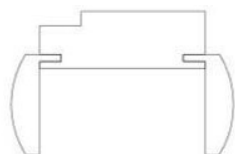

SQUADRO +  
BAROCCO

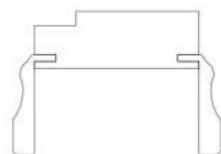

SQUADRO +  
IMPERO

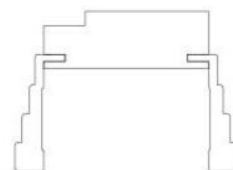

SQUADRO +  
LISCIO 7

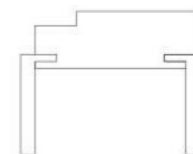

COMPLANARE ESTERNO

SQUADRO +  
LISCIO 7

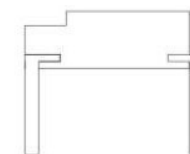

COMPLANARE INTERNO

SQUADRO

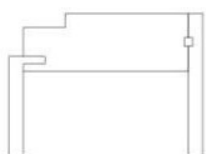

LISCIO 10 A FILO ESTERNO  
LISCIO 7 INTERNO

SQUADRO



LISCIO 10 A FILO ESTERNO LISCIO  
7 COMPLANARE INTERNO

SQUADRO INVERSO

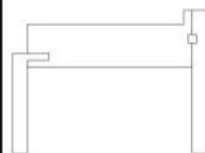

A SPINGERE

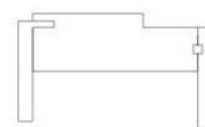

A TIRARE

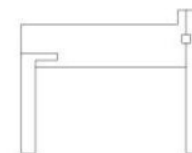

COMPLANARE A  
SPINGERE

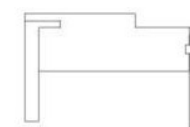

COMPLANARE A  
TIRARE

R10 +  
LISCIO 7

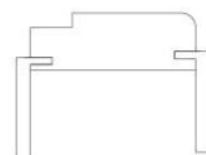

R10 +  
CURVO

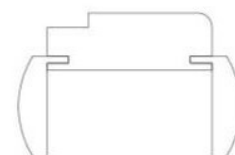

R10 +  
BAROCCO

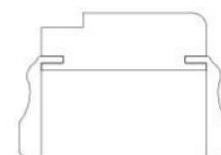

R10 +  
LISCIO 7

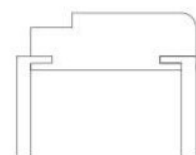

COMPLANARE ESTERNO

R10 +  
LISCIO 7

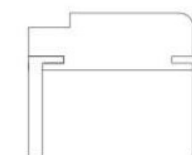

COMPLANARE INTERNO

R30 +  
LISCIO 7

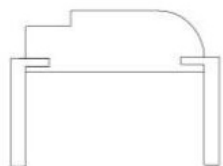

R30 +  
CURVO

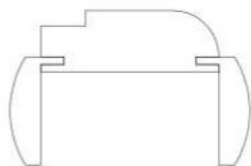

R30 +  
BAROCCO

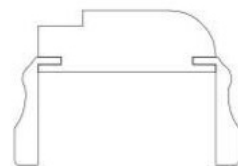

R30 +  
LISCIO 7

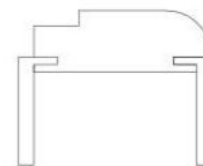

COMPLANARE ESTERNO

R30 +  
LISCIO 7

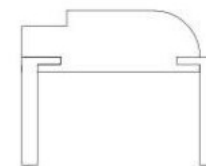

COMPLANARE INTERNO

R50 +  
CURVO

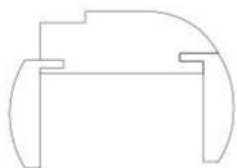

R50 +  
LISCIO 7

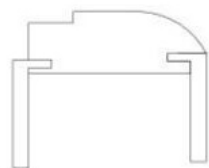

CAPITELLO

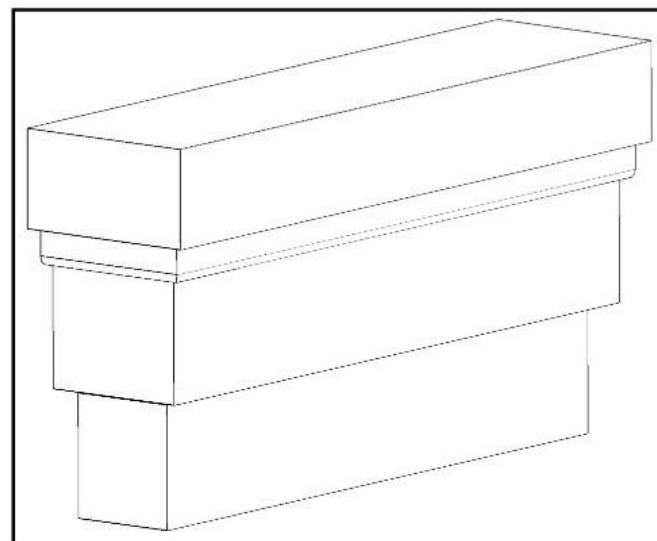

RIDOSO



# SENSI DI APERTURA

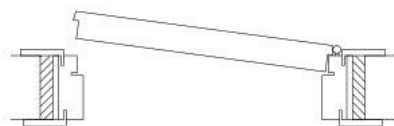

BATTENTE DX

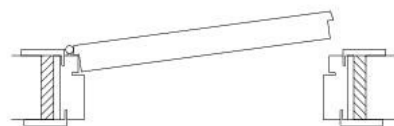

BATTENTE SX

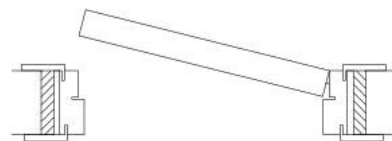

CERNIERE A SCOMPARSA DX

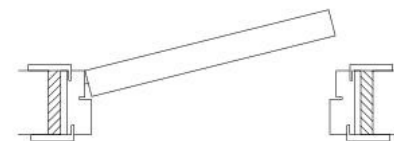

CERNIERE A SCOMPARSA SX



FILO ANTA TIRARE DX



FILO ANTA A TIRARE SX

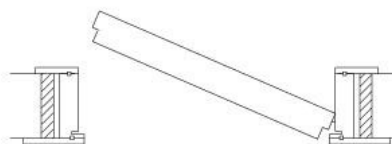

FILO ANTA SPINGERE DX

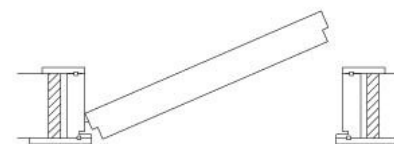

FILO ANTA SPINGERE SX



TELAIO A RIDOSSO DX

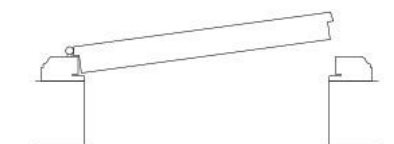

TELAIO A RIDOSSO SX

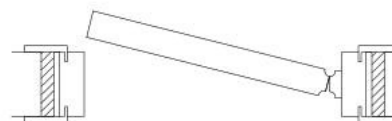

VA E VIENI DX



VA E VIENI SX

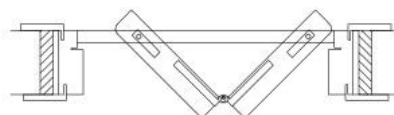

LIBRO 1/2 + 1/2 SISTEMA 1 DX

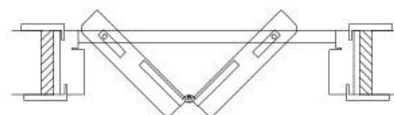

LIBRO 1/2 + 1/2 SISTEMA 1 SX

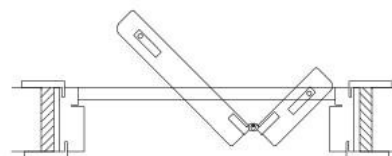

LIBRO 1/3 2/3 SISTEMA 1 DX

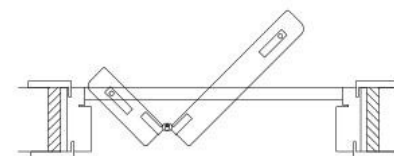

LIBRO 1/3 2/3 SISTEMA 1 SX

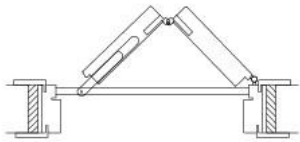

LIBRO 1/2 + 1/2 SISTEMA 2 DX

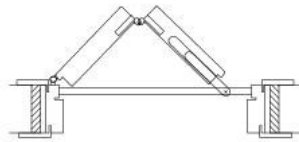

LIBRO 1/2 + 1/2 SISTEMA 2 SX

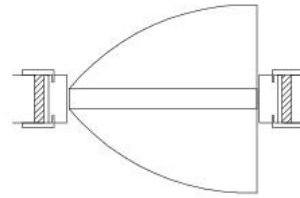

ROTOTRASLANTE DX

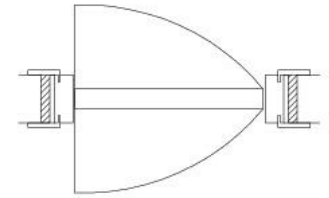

ROTOTRASLANTE SX

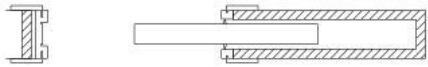

SCORREVOLE SCOMPARSA 1 ANTA DX

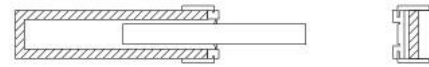

SCORREVOLE SCOMPARSA 1 ANTA SX



SCORREVOLE ESTERNO CON BATTUTA DX



SCORREVOLE ESTERNO CON BATTUTA SX

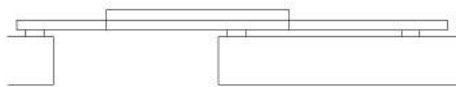

SCORREVOLE ESTERNO DIVA DX

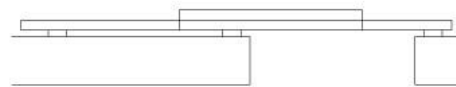

SCORREVOLE ESTERNO DIVA SX

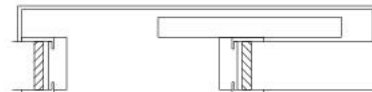

SCORREVOLE ESTERNO DX

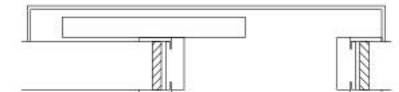

SCORREVOLE ESTERNO SX



SCORREVOLE ESTERNO MINIMAL DX



SCORREVOLE ESTERNO MINIMAL SX



SCORREVOLE "MAGIC" DX



SCORREVOLE "MAGIC" SX



SCORREVOLE PARALLELO ESTERNO DX



SCORREVOLE PARALLELO ESTERNO SX



SCORREVOLE PARALLELO INTERNO

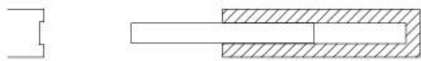

SCORREVOLE FILO MURO DX

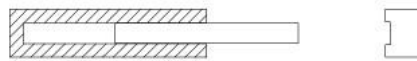

SCORREVOLE FILO MURO SX

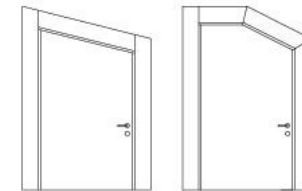

TRAPEZIO



SCORREVOLE SCOMPARSA 2 ANTA

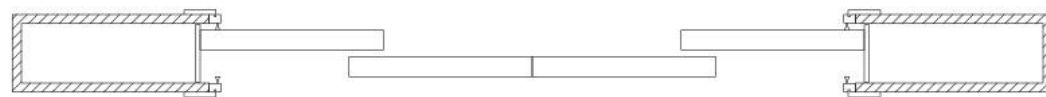

SCORREVOLE SCOMPARSA 4 ANTE



# FINITURE FERRAMENTA / VETRO

---



OTTONE SATINATO



OTTONE LUCIDO

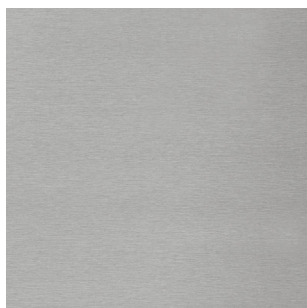

CROMO SATINATO

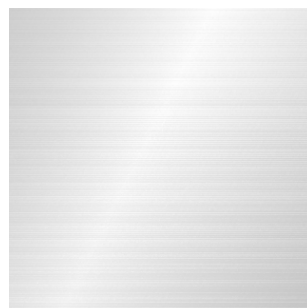

CROMO LUCIDO



BRONZO

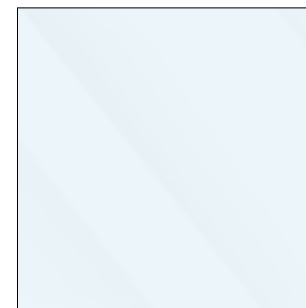

VETRO TRASPARENTE



VETRO SATINATO



VETRO BIANCO LATTE  
EXTRA CHIARO



# MANIGLIE

QUADRA



TONDA

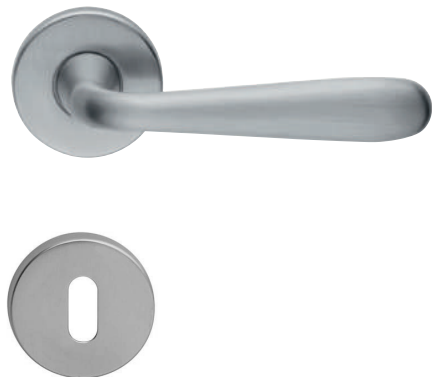

KIT E TONDO



KIT E QUADRO



DUETTO TONDO



KIT A TONDO



KIT A QUADRO



DUETTO QUADRO



# ESSENZE LEGNO

---



30/N TANGANICA



31/N CASTAGNO



32/N TANGANICA



33/N CASTAGNO



34/N TANGANICA



35/N OLMO



36/N TANGANICA



37/N OLMO



38/N MOGANO



39/N TOULIPER



40/N PINO



41/N NOCE NAZIONALE



42/N FAGGIO



43/N NOCE BIONDO



44/N ROVERE



45/N FRASSINO



46/N ROVERE



FRASSINO SALE-PEPE /N



48/N ROVERE SBIANCATO



49/N CILIEGIO



50/N ROVERE TINTO WENGHÉ



51/N ACERO



52/N ROVERE EFFETTO  
NATURALE



53/N LACCATO ANTICO



54/N MASSELLO TOULIPIER  
CERA



55/N MASSELLO TOULIPIER  
GOMMA LACCA



56/N MASSELLO ROVERE  
CERA



57/N MASSELLO ROVERE  
GOMMA LACCA



58/N ROVERE RUSTICATO  
CERA



59/N FRASSINO RUSTICATO  
LACCATO



60/N CANALETTO



CASTAGNO RIGATO EFFETTO  
NATURALE/N



FRASSINO DECAPÉ COFAS/N



FRASSINO DECAPÉ GREY/N

# ESSENZE LACCATI

---



LACCATO BIANCO COFAS/N



LACCATO RAL. 9010/N

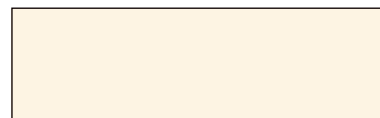

LACCATO RAL. 9001/N



LACCATO RAL. 1013/N



LACCATO RAL. 7047/N



LACCATO RAL. 7036/N



LACCATO RAL. 7044/N



LACCATO RAL. 1019/N

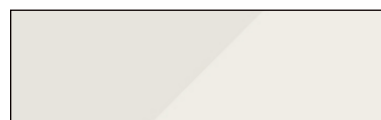

LACCATO BRILLANTE RAL.  
9010/N



LACCATO BRILLANTE RAL.  
7047/N



FRASSINO LACCATO  
BIANCO COFAS/N



FRASSINO LACCATO  
RAL. 9010/N



FRASSINO LACCATO  
RAL. 9001/N



FRASSINO LACCATO  
RAL. 1013/N

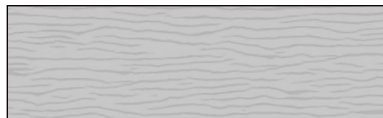

FRASSINO LACCATO  
RAL. 7047/N



FRASSINO LACCATO  
RAL. 7036/N



FRASSINO LACCATO  
RAL. 7044/N

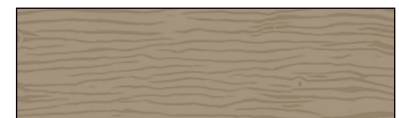

FRASSINO LACCATO  
RAL. 1019/N

CATALOGO REALIZZATO DA:

**MICHAEL FELICI**

*the Studio*

AGENZIA PUBBLICITARIA E CREATIVA

**MICHAELFELICI.COM**

RENDERING REALIZZATI DA:

**IL RENDER by FABIO FABBRI**

Le immagini dei prodotti sono puramente indicative.  
Potrebbero pertanto non essere perfettamente rappresentative delle caratteristiche reali del prodotto

COFAS S.p.a.  
Strada Tane di Baragone, 23  
47899 Galazzano (RSM)

Tel: 0549 901040  
Fax: 0549 901452  
info@cofas-spa.com

*Il valore di una porta,  
il lavoro di una vita.*

www.cofas-spa.com  
cofasgroup

